AEG SOLAR MODULES

AEG

INSTALLATION MANUAL

VERSION: GD202311 V1-23



GLASS-GLASS (DOUBLE GLASS)
MODULE SERIES:

AS-MXXX2 / AS-MXXX3 / AS-MXXX8 / AS-MXXXX*

*X in Product Name Code indicates a placeholder for the factory code; on the solar module it will be indicated with a single digit from 1 to 9. Please refer to the installations instructions of the corresponding type.

AEG GLASS-GLASS SOLAR MODULES INSTALLATION MANUAL

Thank you for choosing the reliability of AEG solar modules.

This installation manual is intended for dealers and installers involved in the planning, installation and commissioning of photovoltaic systems deploying AEG solar modules. These instructions provide you with valuable information to ensure that your PV installation runs smoothly and achieves optimal yields over its whole lifecycle.

AEG solar modules are tested and approved by acknowledged independent certification authorities and can only be installed by qualified professional companies.

Please observe the standards and regulations applying to photovoltaic systems in the relevant countries, as well as the rules of the employers' liability insurance associations for accident protection. Failure to comply with these can result in major injuries and damage.

Keep this guide in a safe place for further reference as it contains important information for product care, maintenance and disposal.

CONTENTS



1. Preliminary remarks	2
1.1 Icons	2
1.2 Product Identification	3
2. Safety	3
2.1 General safety	3
2.2 Handling safety	3
2.3 Installation safety	4
3. Installation	5
3.1 General remarks	5
3.2 Mechanical installation	5
3.2.1 Bolting	6
3.2.2 Clamping	7

3.2.3 Insertion systems	7
3.2.4 Loading capacity	7
3.3.1 General remarks	7
3.3.2 Electrical installation	8
3.3.3 Grounding	8
4. Maintenance	9
4.1 General maintenance	9
4.2 Cleaning	9
4.3 Module End of Life	9
5. Disclaimer of Liability	10
6. CONTACT	10

1. PRELIMINARY REMARKS

1.1 Icons

This section describes relevant warning symbols recurring in the installation and operation manual of AEG solar modules. Icons highlight relevant information for the physical and property safety of the user. Compliance to the provided instructions is essential to prevent physical injury and product damage. Below is a list of the icons used in this manual:

Icon	Meaning	Instruction
	Danger	Serious physical injury or even death may occur in case of noncompliance with the requirement (electrical hazard)
	Warning	Physical injury or product damage may occur in case of noncompliance with the requirement.
	Prohibited	Damage may occur in case of noncompliance with the requirement.

Icon	Meaning	Instruction
	Note	Useful information for product maintenance and operation is provided

Table 1: Icon meaning

1.2 Product Identification

Each module can be identified by means of the following information:

Product Label

It is placed on the module backside. According to EN 50380 Directives it provides information about the main parameters of the module: Product Type, Maximum Power, Current at Maximum Power, Voltage at Maximum power, Open Circuit Voltage, Short Circuit Current -as measured under Standard Test Conditions, Maximum System Voltage, Maximum Series Fuse etc. The product label also features the Product Name Code (PNC).

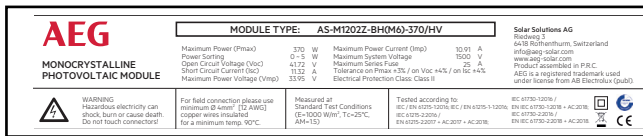

Figure 1: label example

Serial Number

Each individual module is identified by a unique serial number univocally coupled with a barcode. Serial number and barcode are permanently placed on the laminate, under the front glass of the module, and are visible from the module front.

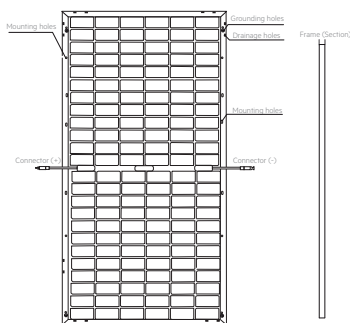

Figure 2: Example of product technical drawings

Please refer to the specific product datasheet on www.aeg-solar.com for the latest technical data.

2. SAFETY

2.1 General safety

All AEG PV modules should be installed according to all local and national applicable standards, codes and regulations. Only qualified personnel should install the solar modules. Installers bear the risk of all injury that might occur during installation including, without limitation, the risk of electric shock. Check and follow all safety precautions specified even for the other components of the system.

Look for any visible damage to the package or the product itself. Double-check the order information and the product nameplate to ensure the products are of the ordered type. Should you find any problems, contact the shipping company and / or your supplier as soon as possible before attempting product installation.

2.2 Handling safety

Please observe the below indications when handling AEG solar modules:

Store the pallets in a ventilated, dry location until installation. Do not open the module boxes during storage or transportation. Inappropriate transport and installation may void the warranty.



Do not apply paint or adhesive to module top surface.

Do not use mirrors or other magnifiers to artificially concentrate sunlight on the modules. Do not expose back sheet foils directly to sunlight. Do not attempt to disassemble the modules. Do not remove any attached nameplates or components. Do not exceed the maximum stapling limitation of 2 pallets (standard packaging for shipment). After unpacking, the modules should be laid horizontally. Do not incline or stack the modules. Do not pile up modules without protections to prevent scratches to the glass and frame. Should the modules need to be piled, they need to be separated by special paper or plastic angles. Do not scratch or damage the module surface.

Do not drill holes in the frame as it may compromise its strength, cause corrosion and void the warranty.

Do not use the junction box and cables as a grip.

Do not drop the module or allow objects to fall on the module.

Do not place any heavy objects on the module to avoid glass breakage.

Do not stand or step on the module.

Do not set the module down hard on a surface.



Do not attempt to repair a module with broken glass or torn backsheet and do not use it as contact with any module surface or the frame could cause an electric shock.

2.3 Installation safety

Installing solar photovoltaic systems requires specialized skills and knowledge. Photovoltaic solar modules are designed for outdoor use, and may be ground mounted as well as mounted on rooftops, vehicles or boats. The proper design of support structures is a responsibility of the system designer and installer. When installing the system, abide with all local, regional and national statutory regulations. Keep children away from the installation site and during transportation and installation of the electrical equipment.

Cover the module completely with a dark opaque material during installation to prevent electricity generation.

When working with modules without any cover, the safety regulations for live electrical equipment need to be followed. Use only equipment, connectors, wiring and support frames suitable for use in a solar electric installation.



Do not wear metallic rings, watchbands, ear, nose or lip rings or other metallic devices while installing or troubleshooting photovoltaic systems in order to avoid electric shock.

Do not disconnect modules under load to avoid electrical arcs.

Contact with electrically active parts of the modules, such as terminals, can result in burns, sparks and lethal shock whether or not the module is connected.

Do not insert electrically conductive parts into the plugs and sockets.

Do not install solar modules and wiring with wet plugs and sockets.

Exert extreme caution when carrying out any work on

the wiring. High contact voltages can generate in the inverter when it is isolated.

Abide with the safety regulations for all the other components used in the PV system, including wiring and cables, connectors, charging regulators, inverters, storage batteries and rechargeable batteries, etc



One individual module may generate DC voltages greater than 30 V when exposed to light of any intensity. Contact with a DC voltage of 30 V or more is potentially hazardous. The series or parallel connection of the modules increases the voltage or electric current respectively. The electrical characteristics are within the following tolerances of the indicated values of I_{sc} , V_{oc} and P_{mpp} under standard test conditions (irradiance of 1000 W/m², AM 1.5 spectrum, and a cell temperature of 25 °C/77 °F).

For the tolerance of the individual module series, please refer to the related Annexes.

Under normal conditions, a photovoltaic module is likely to experience conditions that produce more current and/or voltage than reported at standard test conditions.

Accordingly, depending on the local regulations, an additional 1.25 multiplier for the I_{sc} (giving a total multiplier of 1.56) and V_{oc} marked on the module when determining component voltage ratings, conductor current ratings, minimum factor of fuse sizes, and size of controls.

Maximum reverse current \leq Maximum series fuse rating measurements reveal opposite polarity or a voltage difference greater than 10V between the strings, check their structural configuration before proceeding with the connection.

2.4 Fire safety

AEG PV modules are tested according to the provisions of IEC EN 61730 Directive with Application Class A (equivalent to Safety Class II requirements). Fire safety has been rated as Class C.



Please be aware that rooftop installations can affect the fire safety of a building. A photovoltaic system composed of IEC 61730-2 certified modules mounted on a UL 61730 certified mounting system should be evaluated in combination with roof coverings with respect to meet the same fire classification as the roof assembly.

Mounting systems with a system fire class rating (Class A, B or C), tested in conjunction with fire class C rated

modules, are considered acceptable for use with AEG solar modules, providing the mounting system does not violate any other requirements of this manual.

Any mounting system limitations on inclination or accessories required to maintain a specific System Fire Class Rating should be clearly specified in the installation instructions and corresponding certification of the mounting system supplier.

When installing modules, ensure the supporting roof has a fire resistant roof covering rated for the application. The fire rating for this module is only valid when the product is installed as specified in the mechanical mounting instructions.

Do not install the solar panels in the proximity of sources of flammable gases and vapors or open flames.

3. INSTALLATION

3.1 General remarks

AEG PV modules should be installed in a location where they can receive the maximum amount of sunlight throughout the year. In the Northern Hemisphere modules should face south, while in the Southern Hemisphere they should face north. The modules should not be shaded at any time by trees, antennas, cables, houses etc. If a module is shaded or even partially shaded, it will fail to perform at ideal conditions and this will result in lower power outputs.

AEG PV modules connected in series should be installed at the same orientation and tilt angle. Different orientations or angles may cause a loss of power output due to the change in sunlight exposure. Dust building up on the surface of the modules can impair module performance. Solar Solutions recommends installing the modules with a tilt angle of at least 10 degrees, making it easier for dust to be washed off by rain. When designing the final layout of the modules in a photovoltaic system, keep suitable access space to allow easy maintenance and inspection works. Provide adequate ventilation under the modules for cooling.

Always use structures and materials specifically developed and certified for photovoltaic module

installation.

AEG PV modules must be installed and stored in the following conditions:

Operating temperature	From -30°C to +50°C
Extreme weather cond.	From -40°C to +85°C
Storage temperature	Up to 30°C
Humidity	Below 85% R.H.

The maximum altitude the solar module is designed for $\leq 2000\text{m}$. Please consult the AEG technical support for more information on the use of modules in special climates, such as an altitude higher than 2000 m.



Do not carry out the installation in high winds and prevent the falling of objects from the roof. Secure the work area so that nobody on or beneath the roof can be injured.

When installing a module on a roof or building, please ensure that it is securely fastened and cannot fall as a result of wind or snow loads.

The modules should not be immersed in liquid. Corrosion risk incurs if the module is exposed to salt (i.e. marine environments) or sulfur sources. The installation distance of the modules to sea water or lakes should therefore be at least 500 m unless otherwise specified. The module should not be exposed to unusual chemical loads. For fire safety indications, please see 2.4 "Fire safety".

Protect the solar modules from overvoltage, e.g. voltage peaks of battery charges, generators, etc. If the module has to be connected to a storage battery, all precautions as prescribed by the battery manufacturer should be taken into account

3.2 Mechanical installation

AEG PV modules can be installed in either landscape or portrait orientation. Please consider the details for individual module types as laid out in the next paragraphs. In choosing the orientation, please keep in mind the internal PV module bypass diode configuration to ensure the optimum electrical behavior from any potential shading over the module. Ensure modules are not subjected to wind or snow loads exceeding the maximum permissible loads, and are not subject to

excessive forces due to the thermal expansion of the support structures. Ensure that the drainage holes of the PV module do not incur in blockage. Do not dismount, drill or modify the frame or any other part of the PV module, as this will void the warranty. Please contact our Technical Service should you need any clarification concerning the installation instructions.

If the modules are unpacked but not installed immediately, please wrap the connectors to prevent damage caused by wind or rain. Do not use any lubricant on connectors and do not remove the waterproof rubber rings from the junction box or connectors.

The module mounting structure must be made of durable, corrosion-resistant and UV-resistant material. A tested and certified mounting structure approved for the considered system design should be used. Ensure the installation method and mounting structure are able to withstand the load conditions. Always observe the instructions and safety precautions of the mounting structure. In regions with heavy snowfall in winter, select the height of the mounting structure so that the lowest edge of the module is not covered by snow at all times. In addition, ensure that the lowest portion of the module is high enough not to be shaded by plants, trees or dirtied by soil.

Modules must be securely attached to the mounting structure. For clamping system installation, follow the instructions provided by the clamping system supplier.



Avoid exposing the frame to lateral tension and pressure, as this might crush the glass or spark a fire. Consider the linear thermal expansion of the frames: the recommended minimum distance between two modules is 1 cm.

For ground-mounted systems, the minimum distance recommended from the ground to the module bottom is at least 60 cm (24 inches).

For roof-mounted systems, always ensure the suitability of the roof construction before installing the modules on a roof. In addition, any point of roof penetration required to mount the modules must be properly sealed to prevent leaks.

Provide adequate ventilation under the modules in conformity to local regulations. A minimum distance of 10 cm between the roof plane and the frame of the module is generally recommended. Never allow modules to overlap or to exceed the rooftop size.

AEG PV modules can be installed with:

- frame mounting holes and bolts – See 3.2.1 “Bolting”
- pressure clamps – See 3.2.2 “Clamping”
- insertion systems - See 3.2.3 „Insertion systems“

3.2.1 Bolting

Always observe the instructions and safety precautions of the mounting system. Modules must be securely fixed to the mounting system (support rails) using the provided mounting holes. There are 4 (four) mounting holes placed to optimize the load handling capability of the module and to secure it to the supporting structure. If increased wind or snow-loads are expected, the additional mounting holes provided should be used. It is recommended to use corrosion proof (stainless steel) hardware. Stainless steel M6 bolts (for 11,5 mm holes) / M8 bolts (for 14 mm holes) and a tightening torque between 8-12 N•m (for M6 bolts) and 16-23 N•m (for M8 bolts) are suggested. When using frame height of 30 mm it is recommended to select a fastener with length $L \leq 20$ mm while mounting the modules with bolts. Please check with your system designer or installer the specific load calculations for your plant; please refer to the Annexes at the end of the manual for information on your specific product series.

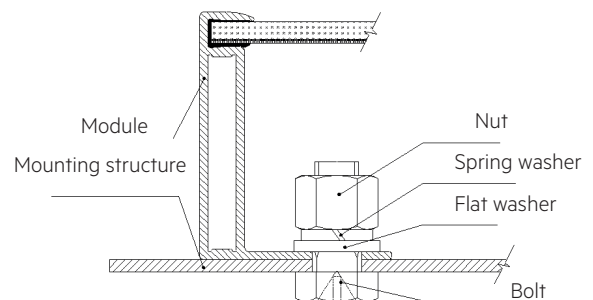

Figure 3: Example of bolting

3.2.2 Clamping

Installation using pressure clamps can be done on both sides of the module frame. Use at least 4 (four) clamps per module, two on each long side of the module (for portrait orientation) or two on each short side of the module (for landscape orientation). Depending on the local wind and snow situation, additional clamps might be required to ensure the module is able to withstand the load. Module clamps should not come into contact with the front glass and should not deform the frame. Ensure to avoid shadowing from module clamps. Please refer to the Annexes at the end of the manual for information on

your specific product series.

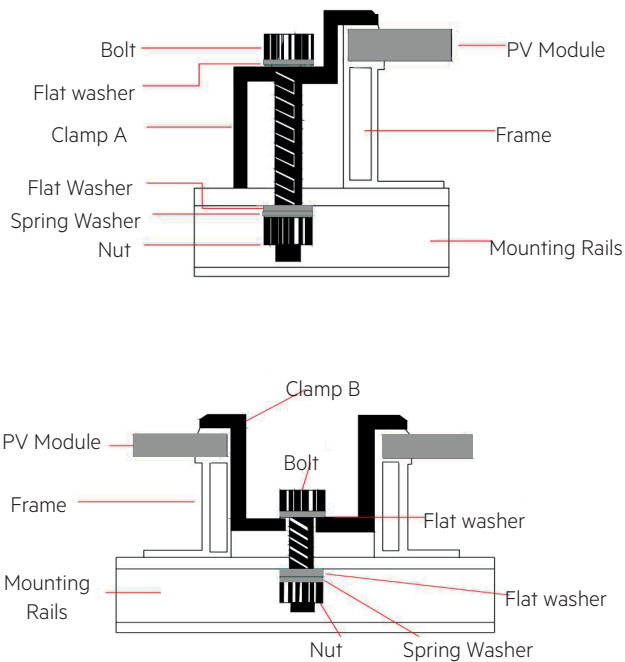

Figure 4: Examples of clamping

3.2.3 Insertion systems

AEG solar modules are compatible with the insertion systems of selected manufacturers. For more information, and for a compatibility assessment of the insertion system you wish to use, contact the AEG service team (see Section 6 „Contact“).

3.2.4 Loading capacity

The PV module's load resistance is rated as:
Wind load: 2400 Pa / Snow load: 5400 Pa.
Please note this could vary according to the different mounting systems and configurations.

For standard conditions, low loading capacity applies: AEG modules are tested under a maximum positive pressure of 2400 Pa, and negative pressure of 2400 Pa; they are designed to meet a maximum positive pressure of 1600 Pa, and negative pressure of 1600 Pa.

For extreme conditions (e.g.: heavy snow), high loading capacity applies: AEG modules are tested under a maximum positive pressure of 5400 Pa, and negative pressure of 2400 Pa; they are designed to endure a maximum positive pressure of 3600 Pa, and negative pressure of 1600 Pa. Both low and high load design

were tested with a safety factor of 1.5 times.

The project's design loads depend on construction, applicable standards, location and local climate. Determination of the design loads is the responsibility of the racking suppliers and/or professional engineers. For detailed information, please follow the local structural code or contact your professional structural engineer.

3.3 Electrical Installation and Grounding

3.3.1 General remarks

Modules electrically connected together in a series/parallel configuration generate DC electrical energy, which can be converted to AC by mean of a solar inverter. When modules are connected in series, the total voltage is equal to the sum of individual voltages. For applications requiring high currents, photovoltaic modules can be connected in parallel; the total current is equal to the sum of individual currents.

The resulting PV system can then be connected to the local utility grid system. As the policies of local utilities and technical rules concerning the connection of renewable energy systems to power grids vary from region to region, please consult a qualified system designer or integrator to design a system compliant with the related directives. Permits are normally required for installing a PV system and the utility must formally approve and inspect the system before its connection to the grid can be accepted. The connection of the inverter to the grid needs to be done by a competent, authorized company. The electrical installation of the PV system must be carried out in accordance with the respective National Electrical Codes or applicable National Regulations.

3.3.2 Electrical installation

To avoid mismatch, power loss or damage to the PV system, do not use different module types within the same circuit.

The modules are fitted with two pre-assembled sunlight resistant, isolated cable leads, which end with PV fast connectors for the electrical connection of the system (positive [+] and negative [-] terminals). Connectors are Multi-Contact (MC4) or Multi-Contact compatible (MC4-compatible). Cables and connectors must not be removed or cut off.

The connectors used must meet the IP68 water-tight standard after being connected. However, it is not recommended to use the connector under water for a long time. Connectors and bypass diodes from different manufacturers should not be mated together. If you need to replace connectors, please contact us.

i Refer to the electrical parameters reported on the label of the module when selecting the size of the cables connecting the module strings to the solar inverter. For electrical design considerations, when determining component voltage ratings, conductor current ratings, fuse sizes and the rest of electrical hardware connected to the module strings, the values provided on the module label or on the related datasheet should be multiplied by a factor of 1.25 for Open Circuit Voltage (Voc) and additional 1.25 multiplier for the Isc (giving a total multiplier of 1.56). Please consult rated local wiring regulations to determine system wire size, type, and temperature rating of conductors to be connected to module connectors.

The maximum number of series connected modules depends on system design, the type of inverter used and environmental conditions. Always ensure that the modules are assembled with the appropriate string fuse for circuit protection based on the maximum series fuse rating of the module and local electrical installation codes.

There is no specific limitation on the number of modules that can be connected in parallel; the number of modules is determined by system design parameters such as current or power output.

To prevent the cables and the connectors from overheating, the cross section of the cables and the capacity of the connectors must be selected to suit the maximum system short circuit current. The recommended PV wire should have a cross section of minimum 4mm².

As stated above, for determination of maximum number of solar modules connected in parallel or in series, the values provided on the module label or on the related datasheet should be multiplied by a factor of 1.25 for Short Circuit Current (Isc) (with additional factor of 1.25), Open Circuit Voltage (Voc) and fuse rating.

3.3.3 Grounding

Please refer to the respective National Electrical Code requirements and standards for safety-related grounding of racking system and/or module frames. AEG PV Modules use an anodic oxidized aluminum frame; modules should hence be connected to the equipment grounding conductor to prevent electrical shock.

 The frame rails have pre-drilled holes marked with a grounding sign. The grounding holes should be used for grounding purposes only and not for module mounting.

Grounding methods:

Use stainless steel bolt and washer to bond the ground wire and aluminum frame through the grounding hole (see figure 7A and 7B). It is recommended to use a 4-14 mm² (AWG 6-12) exposed copper wire as ground wire. For the required bolt and nut types please refer to the national/local electrical regulations.

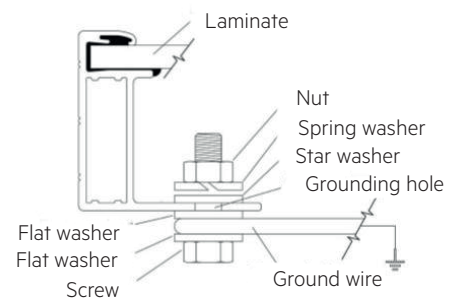

Figure 7A: Grounding Method with Bolt and Washer

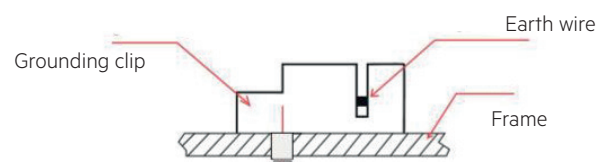

Figure 7B Grounding Clip

Additional third-party grounding devices:
AEG solar modules can be grounded using third-party grounding devices. It is required that these devices are certified for grounding solar modules and are installed according to the manufacturer's instructions.

4. MAINTENANCE

4.1 General maintenance

If any problem arises, have them investigated by a competent specialist; repairing works must be performed by specialized and properly trained personnel only. Improper maintenance can cause lethal electric shock and/or burns.



Use appropriate safety equipment (insulated tools, insulating gloves, etc.) when handling modules.

For any electrical maintenance, the PV system must be shut down first.

Do not touch live parts or cables and connectors.

Do not disconnect the grounding when doing system maintenance works.



We recommend the following maintenance in order to ensure an optimum performance of the module:

Check the electrical and mechanical connections every six months to verify that they are clean, secure and undamaged.

Check that mounting hardware, terminal screws and grounding components are tightly secured and are not affected by corrosion.

Replacement modules must be of the same type of those to be replaced.

Modules generate high voltage when exposed to sunlight. Cover the front surface of modules with an opaque and not scratching material during maintenance. Follow the maintenance instructions for all components used in the system, such as support frames, charge regulators, inverters, batteries etc.

4.2 Cleaning



Do not clean modules with broken glass or exposed wiring. This can cause a general electrical failure of the module or electrical shock hazard.

Dirt and dust can accumulate on the glass surface of the PV module over time, particularly in installations with low inclination. This can cause a general decrease of power output and also sedimentation on the lower edge of the modules due to dirt accumulation. We recommend

a periodic cleaning of PV modules to ensure maximum power output, especially in regions with high quantity of dust in the air or low precipitations as follows:

Under most weather conditions, normal rainfall is enough to keep the PV module glass surface clean. Clean the glass surface of the module as necessary and consider that lower inclination requires higher cleaning frequency.

Always use water and a soft sponge or cloth for cleaning. A mild, non-abrasive cleaning agent can be used to remove stubborn dirt. High mineral content water is not recommended, as it may leave residual deposits on the module.

To avoid a possible thermal shock clean the modules during early morning, when the module is still cold. This is especially recommended in regions with hotter temperatures.

In cold environments with snow do not try to remove the frozen snow or ice from the module scratching on the front glass. Only soft snow can be removed gently with a soft brush.

Do not use abrasive sponges or aggressive tools that could scratch the module surface; under no circumstance should the dirt be dry removed, as this would cause micro-scratches which could have a negative impact on the module's performances.

4.3 Module End of Life

Please return any electrical equipment that you no longer use to the collection points provided for their disposal. Information concerning where the equipment can be disposed of can be obtained from your local authorities.



The wheeled bin symbol on the AEG product labels means that the equipment shall be disposed of as special waste in accordance to the local regulations.

5. DISCLAIMER OF LIABILITY

The use of this manual and the conditions or methods of installation, operation, use and maintenance of the

product are beyond Solar Solutions's control. Solar Solutions expressly disclaims liability for loss, damage, or expense arising out of or in any way connected with such installation, operation, use or maintenance.

No responsibility is assumed by Solar Solutions AG for any infringement of patents or other rights of third parties, which may result from use of the PV product. No license is granted by implication or otherwise under any patent or patent rights.

6. CONTACT

Solar Solutions AG
Riedweg 3
6418 Rothenthurm, Switzerland
www.aeg-solar.com
Mail: service@solarsolutions.ag

AEG is a registered trademark used under license from AB Electrolux (publ).



ANNEX 1A - PRODUCT SERIES AS-MXXX2

AS-M1082-BH(RM10) / HV, AS-M1202-BH(M6) / HV
 also including the variants „Transparent glass and Black frame“ („Z“), „Black pattern on back side and Black frame“ („B“),
 „White pattern on back side and Silver frame“ („W“), „White pattern on back side and Black frame“ („Y“)

TOLERANCES (see manual 2.3 „Installation safety“)

The electrical characteristics of the products are within the following tolerances of the indicated values of Isc, Voc and Pmpp under standard test conditions (irradiance of 1000 W/m², AM 1.5 spectrum, and a cell temperature of 25 °C/77 °F): Isc ±3% / Voc ±3% / Pmpp ±4%.

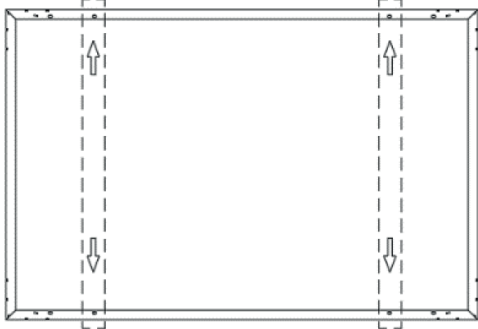
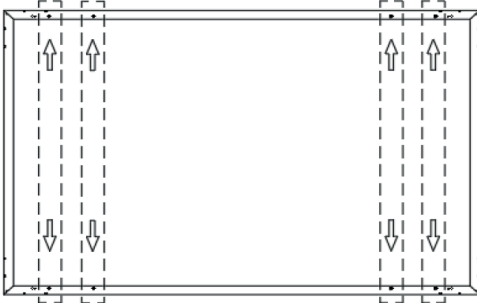
LOADING CAPACITY (see manual 3.2.4 „Loading capacity“)

AS-M1202-BH(M6) / HV, AS-M1082-BH(RM10) / HV			
Mounting with bolts			
4 bolts cross the long frame (inner holes)		8 bolts at the long frame	
AS-1082-BH(RM10) / HV	Test load: positive 5400Pa / negative 2400Pa	AS-1082-BH(RM10) / HV	Not Available
	Design load: positive 3600Pa / negative 1600Pa		
AS-M1202-BH(M6) / HV	Test load: positive 5400Pa / negative 2400Pa	AS-M1202-BH(M6) / HV	Test load: positive 5400Pa / negative 3600Pa
	Design load: positive 3600Pa / negative 1600Pa		Design load: positive 3600Pa / negative 2400Pa
			
4 bolts parallel the long frame (inner holes)		4 bolts parallel the long frame (outer holes)	
AS-1082-BH(RM10) / HV	Test load: positive 2400Pa / negative 2400Pa	AS-1082-BH(RM10) / HV	Test load: positive 2400Pa / negative 2400Pa
	Design load: positive 1600Pa / negative 1600Pa		Design load: positive 1600Pa / negative 1600Pa
AS-M1202-BH(M6) / HV	Not Available	AS-M1202-BH(M6) / HV	Not Available
			

AS-M1202-BH(M6) / HV, AS-M1082-BH(RM10) / HV			
Mounting with clamps			
4 clamps mounting rails cross the long frame		6 clamps mounting rails cross the long frame	
Clamp position: ;		Clamp position: ;	
AS-1082-BH(RM10) / HV	390mm>X≤490mm	AS-1082-BH(RM10) / HV	Not Available
	Test load: positive 5400Pa / negative 2400Pa		
	Design load: positive 3600Pa / negative 1600Pa		
AS-M1202-BH(M6) / HV	$X = 1/4 L \pm 50 \text{ mm}$	AS-M1202-BH(M6) / HV	$X = 1/6 L \pm 50 \text{ mm}; Y = 1/2 L \pm 30 \text{ mm}$
	Test load: positive 5400Pa / negative 2400Pa		Test load: positive 5400Pa / negative 3600Pa
	Design load: positive 3600Pa / negative 1600Pa		Design load: positive 3600Pa / negative 2400Pa
4 clamps mounting on the short frame		Short-side in-rail installation and long-side reinforcement with clamps	
Clamp position: ;		Clamp position: ;	
AS-1082-BH(RM10) / HV	Starting directly at the outer edge of the module on the short frame side in the length of the clamp	AS-1082-BH(RM10) / HV	Not Available
	Test load: positive 2400Pa/ negative 1600Pa		
	Design load: positive 1067Pa, negative 1067Pa		
AS-M1202-BH(M6) / HV	$X = 1/4 W; 0 < X < 1/4 W$	AS-M1202-BH(M6) / HV	$X = 1/2 L \pm 30 \text{ mm}$
	Test load: positive 2400Pa/ negative 1600Pa		Test load: positive 2400Pa/ negative 1600Pa
	Design load: positive 1600Pa, negative 1067Pa		Design load: positive 3600Pa, negative 1600Pa

AS-M1202-BH(M6) / HV, AS-M1082-BH(RM10) / HV

Mounting with rails

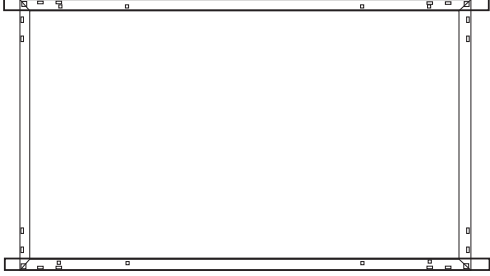
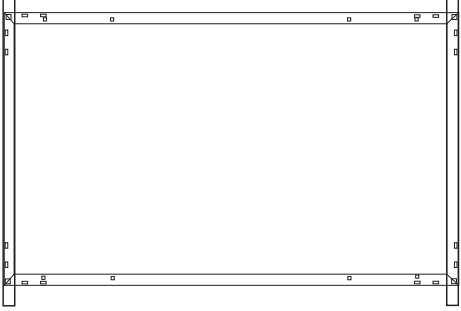
Long-side rail installation		Short-side rail installation	
AS-M1202-BH(M6) / HV	Test load: positive 5400Pa/ negative 2400Pa	AS-M1202-BH(M6) / HV	Test load: positive 2400Pa/ negative 1600Pa
	Design load: positive 3600Pa, negative 1600Pa		Design load: positive 1600Pa, negative 1067Pa
AS-1082-BH(RM10) / HV	Not Available	AS-1082-BH(RM10) / HV	Not Available
			

ANNEX 1B - PRODUCT SERIES AS-MXXX3





AS-M1803-BH(RM10) / HV, AS-M1803-MH(M10) / HV, AS-M1203-MH(M10) / HV, AS-M1443-BH(M10) / HV, AS-M1443-MH(M10) / HV, AS-M1443-BH(RM10) / HV also including the variants „Transparent glass and Black frame“ („Z“), „Black pattern on back side and Black frame“ („B“), „White pattern on back side and Silver frame“ („W“), „White pattern on back side and Black frame“ („Y“)

TOLERANCES (see manual 2.3 „Installation safety“)

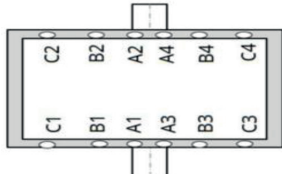
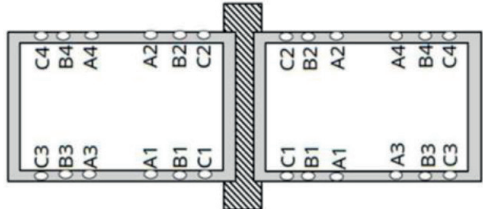
The electrical characteristics of the products are within the following tolerances of the indicated values of Isc, Voc and Pmpp under standard test conditions (irradiance of 1000 W/m², AM 1.5 spectrum, and a cell temperature of 25 °C/77 °F): Isc ±3% / Voc ±3% / Pmpp ±5%.

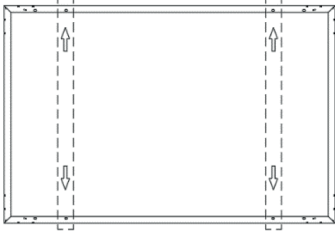
LOADING CAPACITY (see manual 3.2.4 „Loading capacity“)

AS-M1803-BH(RM10) / HV, AS-M1803-MH(M10) / HV, AS-M1203-MH(M10) / HV, AS-M1443-BH(M10) / HV, AS-M1443-MH(M10) / HV, AS-M1443-BH(RM10) / HV			
Mounting with bolts (axis tracker)			
4 bolts, pitch-bolt mounting (for single axis tracker)		4 bolts, pitch-bolt mounting (for double axis tracker)	
AS-M1083-MH(M10) / HV	Not available	AS-M1083-MH(M10) / HV	Not available
AS-M1083-BH(RM10) / HV	Not available	AS-M1083-BH(RM10) / HV	Not available
AS-M1203-MH(M10) / HV	Not available	AS-M1203-MH(M10) / HV	Not available
AS-M1443-MH(M10) / HV	Test load: positive 2100Pa, negative 2100/ positive 3200, negative 2400	AS-M1443-MH(M10) / HV	Test load: positive 1600Pa,negative 1200Pa/ positive 2600, negative 2200
	Design load: positive 3600Pa / negative 1600Pa		Design load: positive 3600Pa / negative 1600Pa
AS-M1443-BH(M10) / HV	Test load: positive 2100Pa, negative 2100/ positive 3200, negative 2400	AS-M1443-BH(M10) / HV	Test load: positive 1600Pa,negative 1200Pa/ positive 2600, negative 2200
	Design load: positive 3600Pa / negative 1600Pa		Design load: positive 3600Pa / negative 1600Pa
AS-M1443-BH(RM10) / HV	Test load: positive 2100Pa, negative 2100/ positive 3200, negative 2400	AS-M1443-BH(RM10) / HV	Test load: positive 1600Pa,negative 1200Pa/ positive 2600, negative 2200
	Design load: positive 3600Pa / negative 1600Pa		Design load: positive 3600Pa / negative 1600Pa
			
AS-M1803-BH(RM10) / HV, AS-M1803-MH(M10) / HV, AS-M1203-MH(M10) / HV, AS-M1443-BH(M10) / HV, AS-M1443-MH(M10) / HV, AS-M1443-BH(RM10) / HV			
Mounting with bolts			
4 bolts at the long frame (inner holes)		4 bolts at the long frame (outer holes)	
AS-M1083-BH(RM10) / HV	Test load: positive 5400Pa / negative 2400Pa	AS-M1083-BH(RM10) / HV	Test load: positive 5400Pa / negative 2400Pa
	Design load: positive 3600Pa, negative 1600Pa		Design load: positive 3600Pa, negative 1600Pa
AS-M1083-MH(M10) / HV (990mm distance)	Test load: positive 5400Pa / negative 2400Pa	AS-M1083-MH(M10) / HV (990mm distance)	Test load: positive 5400Pa / negative 2400Pa
	Design load: positive 3600Pa, negative 1600Pa		Design load: positive 3600Pa, negative 1600Pa
AS-M1203-MH(M10) / HV (1100mm distance)	Test load: positive 5400Pa / negative 2400Pa	AS-M1203-MH(M10) / HV (1100mm distance)	Test load: positive 3600Pa / negative 2400Pa
	Design load: positive 3600Pa, negative 1600Pa		Design load: positive 3600Pa / negative 1600Pa
AS-M1443-BH(RM10) / HV	Test load: positive 5400Pa / negative 2400P	AS-M1443-BH(RM10) / HV	Test load: positive 3600Pa / negative 2400Pa
	Design load: positive 3600Pa, negative 1600Pa		Design load: positive 3600Pa / negative 1600Pa

AS-M1443-MH(M10) / HV	Test load: positive 5400Pa / negative 2400Pa	AS-M1443-MH(M10) / HV	Test load: positive 3600Pa / negative 2400Pa
	Design load: positive 3600Pa, negative 1600Pa		Design load: positive 3600Pa / negative 1600Pa
AS-M1443-BH(M10) / HV (1400mm distance)	Test load: positive 5400Pa / negative 2400Pa	AS-M1443-BH(M10) / HV (1400mm distance)	Test load: positive 3600Pa / negative 2400Pa
	Design load: positive 3600Pa, negative 1600Pa		Design load: positive 3600Pa / negative 1600Pa
			
AS-M1803-BH(RM10) / HV, AS-M1803-MH(M10) / HV, AS-M1203-MH(M10) / HV, AS-M1443-BH(M10) / HV, AS-M1443-MH(M10) / HV, AS-M1443-BH(RM10) / HV			
Mounting with clamps			
4 clamps vertical to the long frame		4 clamps overlapping the long frame	
Clamp position:  ;		Clamp position:  ;	
AS-M1083-BH(RM10) / HV	X = 266-466mm	AS-M1083-BH(RM10) / HV	X = 266-466mm
	Test load: positive 5400Pa / negative 2400Pa		Test load: positive 3600Pa / negative 2400Pa
	Design load: positive 3600Pa / negative 1600Pa		Design load: positive 3600Pa, negative 1600Pa
AS-M1083-MH(M10) / HV	X = 266-466mm	AS-M1083-MH(M10) / HV	X = 266-466mm
	Test load: positive 5400Pa / negative 2400Pa		Test load: positive 3600Pa / negative 2400Pa
	Design load: positive 3600Pa / negative 1600Pa		Design load: positive 3600Pa, negative 1600Pa
AS-M1203-MH(M10) / HV	X = 320-520mm	AS-M1203-MH(M10) / HV	X = 320-520mm
	Test load: positive 5400Pa / negative 2400Pa		Test load: positive 3600Pa / negative 2400Pa
	Design load: positive 3600Pa / negative 1600Pa		Design load: positive 3600Pa / negative 1600Pa
AS-M1443-MH(M10) / HV	X = 430-530mm	AS-M1443-MH(M10) / HV	X = 430-530mm
	Test load: positive 5400Pa / negative 2400Pa		Test load: positive 3600Pa / negative 2400Pa
	Design load: positive 3600Pa / negative 1600Pa		Design load: positive 3600Pa / negative 1600Pa
AS-M1443-BH(M10) / HV	X = 430-530mm	AS-M1443-BH(M10) / HV	X = 430-530mm
	Test load: positive 5400Pa / negative 2400Pa		Test load: positive 3600Pa / negative 2400Pa
	Design load: positive 3600Pa / negative 1600Pa		Design load: positive 3600Pa / negative 1600Pa
AS-M1443-BH(RM10) / HV	X = 430-530mm	AS-M1443-BH(RM10) / HV	X = 430-530mm
	Test load: positive 5400Pa / negative 2400Pa		Test load: positive 3600Pa / negative 2400Pa
	Design load: positive 3600Pa / negative 1600Pa		Design load: positive 3600Pa / negative 1600Pa

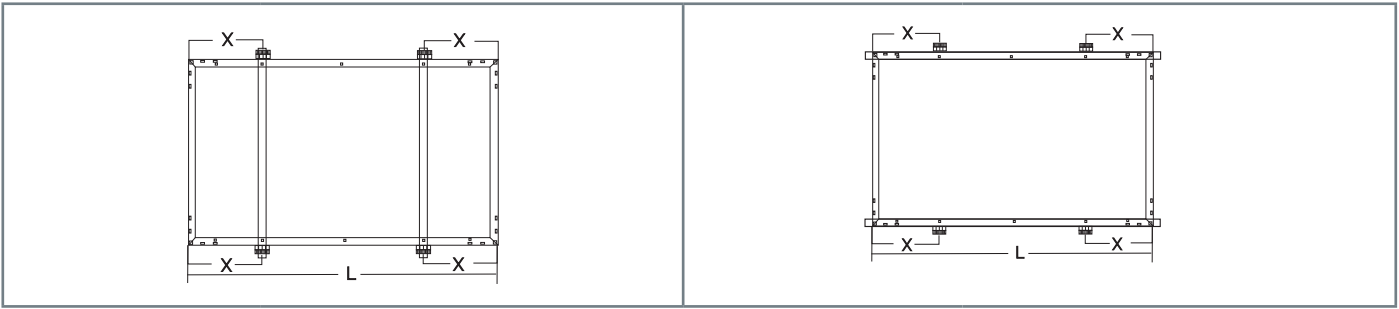

4 clamps mounting to the short frame		4 clamps overlapping to the short frame	
Clamp position: ;		Clamp position: ;	
AS-M1083-MH(M10) / HV	X = 0-250mm	AS-M1083-MH(M10) / HV	X = 150-250mm
	Test load: positive 5400Pa / negative 2400Pa		Test load: positive 5400Pa / negative 2400Pa
	Design load: positive 3600Pa / negative 1600Pa		Design load: positive 3600Pa / negative 1600Pa
AS-M1083-BH(RM10) / HV	X = 0-250mm	AS-M1083-BH(RM10) / HV	X = 150-250mm
	Test load: positive 1200Pa / negative 1200Pa		Test load: positive 5400Pa / negative 2400Pa
	Design load: positive 3600Pa / negative 1600Pa		Design load: positive 3600Pa / negative 1600Pa
AS-M1203-MH(M10) / HV	X = 0-250mm	AS-M1203-MH(M10) / HV	X = 150-250mm
	Test load: positive 900Pa / negative 450Pa		Test load: positive 1800Pa / negative 1800Pa
	Design load: positive 3600Pa / negative 1600Pa		Design load: positive 3600Pa / negative 1600Pa
AS-M1443-BH(M10) / HV	Not available	AS-M1443-BH(M10) / HV	Not available
AS-M1443-MH(M10) / HV		AS-M1443-MH(M10) / HV	
AS-M1443-BH(RM10) / HV		AS-M1443-BH(RM10) / HV	

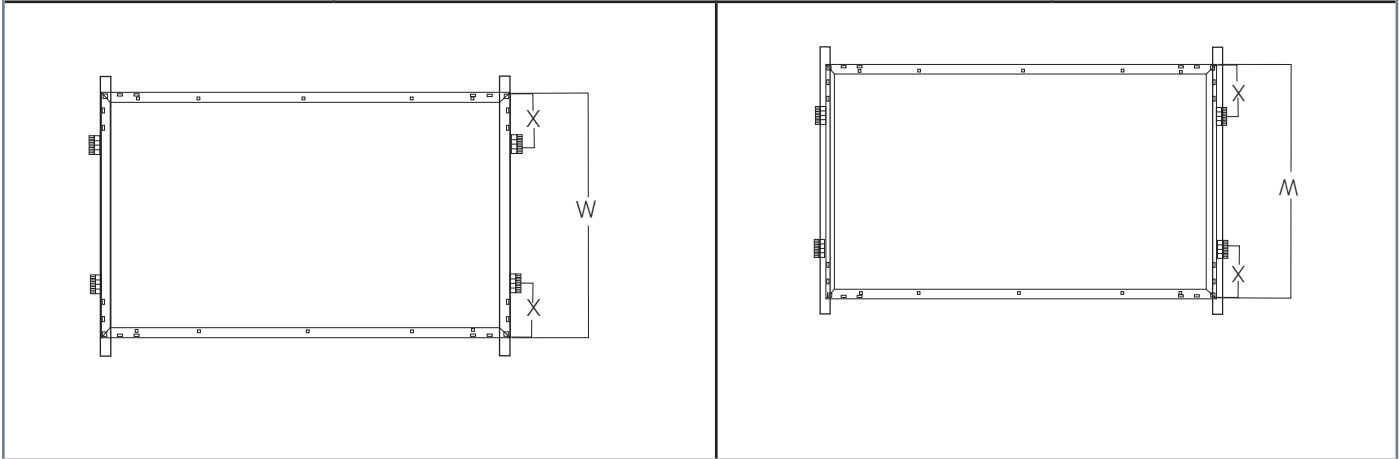

ANNEX 1E - PRODUCT SERIES AS-MXXX8

AS-M1088-BH(M10) / HV, AS-M1208-BH(M10) / HV,
also including the variants „Transparent glass and Black frame“ („Z“), „Black pattern on back side and Black frame“ („B“),
„White pattern on back side and Silver frame“ („W“), „White pattern on back side and Black frame“ („Y“)

TOLERANCES (see manual 2.3 „Installation safety“)

The electrical characteristics of the products are within the following tolerances of the indicated values of I_{sc} , V_{oc} and P_{mpp} under standard test conditions (irradiance of 1000 W/m^2 , AM 1.5 spectrum, and a cell temperature of $25 \text{ }^\circ\text{C}/77 \text{ }^\circ\text{F}$): $I_{sc} \pm 3\%$ / $V_{oc} \pm 3\%$ / $P_{mpp} \pm 3\%$



LOADING CAPACITY (see manual 3.2.4 „Loading capacity“)

AS-M1088-BH(M10) / HV, AS-M1208-BH(M10) / HV

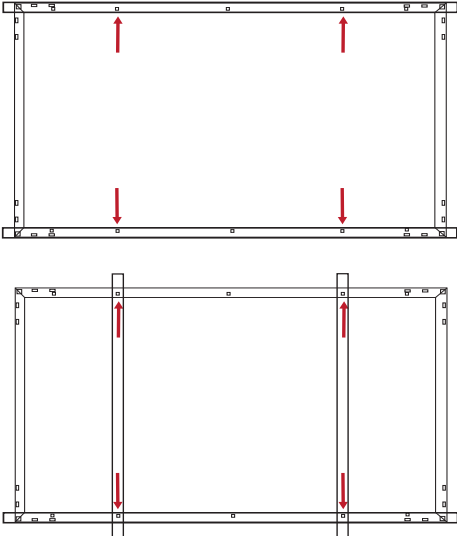
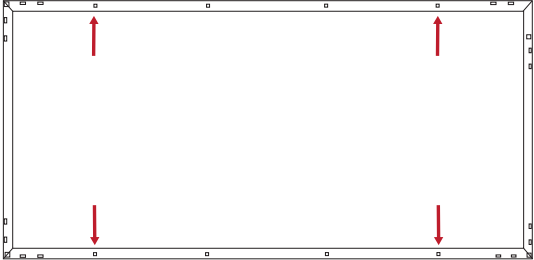

Mounting with bolts

4 bolts at the long frame (inner holes)		4 bolts at the long frame (outer holes)	
AS-M1208-BH(M10) / HV	Test load: positive 5400Pa / negative 2400Pa	AS-M1208-BH(M10) / HV	Test load: positive 3600Pa / negative 2400Pa
	Design load: positive 3600Pa / negative 1600Pa		Design load: positive 2400Pa / negative 1600Pa
AS-M1088-BH(M10) / HV	Test load: positive 5400Pa / negative 2400Pa	AS-M1088-BH(M10) / HV	Test load: positive 5400Pa / negative 2400Pa
	Design load: positive 3600Pa / negative 1600Pa		Design load: positive 3600Pa / negative 1600Pa
			

Mounting with clamps

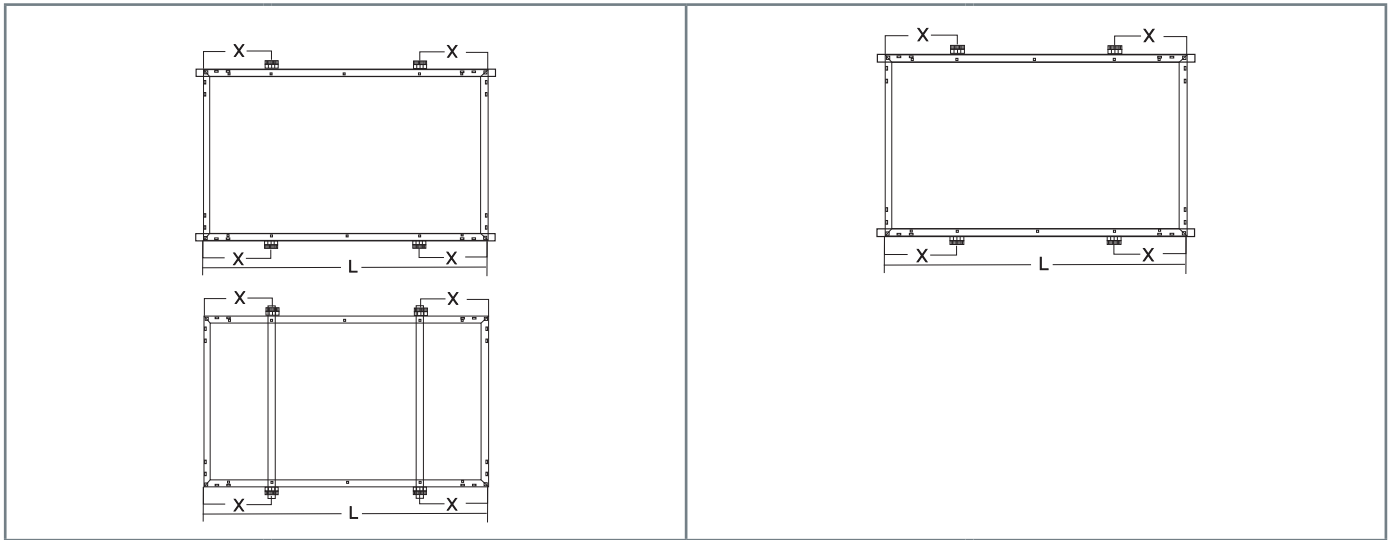
4 clamps vertical to the long frame		4 clamps overlapping the long frame	
Clamp position:  ;		Clamp position:  ;	
AS-M1208-BH(M10) / HV	X = 320-520mm	AS-M1208-BH(M10) / HV	X = 320-520mm
	Test load: positive 5400Pa / negative 2400Pa		Test load: positive 3600Pa / negative 2400Pa
	Design load: positive 3600Pa / negative 1600Pa		Design load: positive 3600Pa / negative 1600Pa
AS-M1088-BH(M10) / HV	X = 266-466mm	AS-M1088-BH(M10) / HV	X = 266-466mm
	Test load: positive 5400Pa / negative 2400Pa		Test load: positive 3600Pa / negative 2400Pa
	Design load: positive 3600Pa / negative 1600Pa		Design load: positive 3600Pa / negative 1600Pa



4 clamps mounting to the short frame		4 clamps overlapping to the short frame	
Clamp position:  ;		Clamp position:  ;	
AS-M1208-BH(M10) / HV	X = 0-250mm	AS-M1208-BH(M10) / HV	X = 150-250mm
	Test load: positive 900Pa / negative 450Pa		Test load: positive 1800Pa / negative 1800Pa
	Design load: positive 600Pa / negative 300Pa		Design load: positive 3600Pa / negative 1600Pa
AS-M1088-BH(M10) / HV	X = 0-250mm	AS-M1088-BH(M10) / HV	X = 150-250mm
	Test load: positive 1200Pa / negative 1200Pa		Test load: positive 1800Pa / negative 1800Pa
	Design load: positive 3600Pa / negative 1600Pa		Design load: positive 3600Pa / negative 1600Pa

